



Valve Actuators

MAXIMATOR air operated valve actuators are piston type design, and are mounted on a manual valve to provide remote control capability. There are two styles of air actuators available, and selection is based on the valve size, system pressure, and air pressure available.

Valve Actuator features:

- ▶ Piston style valve actuator design offers dependable operation and longer actuator cycle life.
- ▶ Yoke style design offers separation from process fluids and actuator air pressure. This design also indicates stem position and allows for easy stem replacement.
- ▶ Actuators are mounted on manual valve bodies to provide remote control capabilities in process applications.
- ▶ Two different size actuators are available to cover varying plant air supplies.
- ▶ Actuators are made of anodized aluminum, which provides good corrosion resistance.
- ▶ Actuators are available in normally open or normally closed configuration.

MAXPRO offers a complete line of high pressure valves, fittings and tubing to compliment the valve actuator line.

Note: When selecting multiple items, the pressure rating would be that of the lowest rated component.

Valve Actuator Index

Air to Open / Normally Closed	2 - 3
Air to Close / Normally Open	4

Maxpro Technologies, Inc.
 7728 Klier Drive South · Fairview Pennsylvania 16415
 Phone: 814-474-9191 · Fax: 814-474-9391
 website: www.maxprotech.com

All general terms and conditions of sale, including limitations of our liability, apply to all products and services sold.
 MT R3 0713



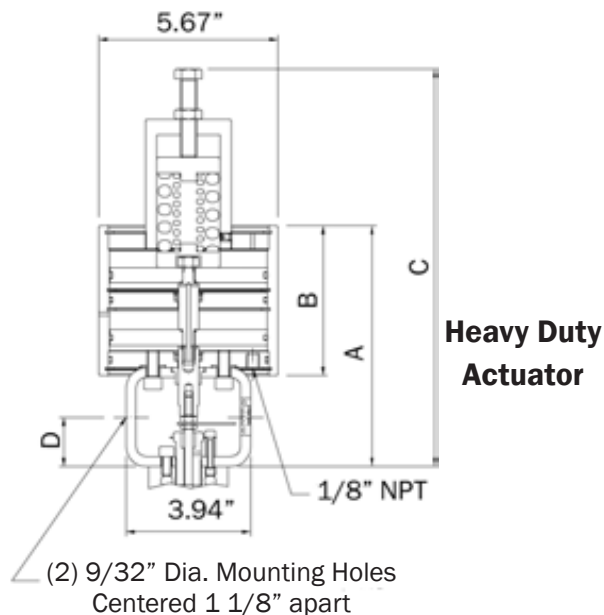
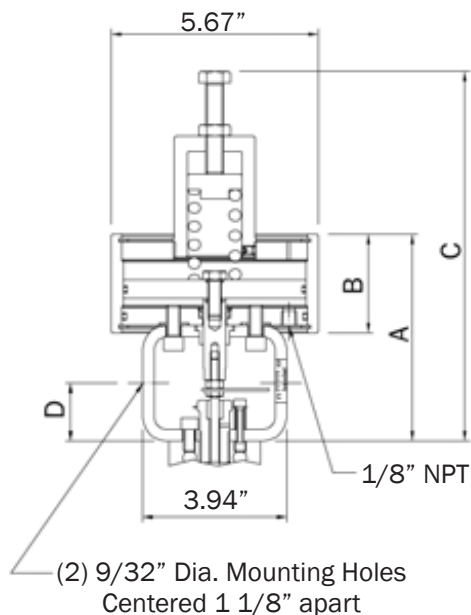

Valve Series	Air Actuator			Air Pressure Required to Open Valve At: System Pressure (ksi)											Max. Pressure (psi)	Flow Value Cv*
	Type	Order Suffix	Data	1-12	14	16	18	20	22	24	26	28	30	36		
36V4	Medium Duty	-YMNC	Air Pressure (psi)	45	55	55	55	55	65	65	65	65	75	85	36,000	0.12
			Spring Pre-comp. (in.)	0.12	0.19	0.19	0.19	0.19	0.25	0.25	0.25	0.25	0.31	0.37		
			Stem Travel (in.)	0.19												
	Heavy Duty	-YHNC	Air Pressure (psi)	25	30	30	30	30	35	35	35	35	40	45	36,000	
			Spring Pre-comp. (in.)	0.12	0.19	0.19	0.19	0.19	0.25	0.25	0.25	0.25	0.31	0.37		
			Stem Travel (in.)	0.19												
36V6, 36V9	Medium Duty	-YMNC	Air Pressure (psi)	55	55	65	65	75	75	75	85	85	95	100	36,000	0.33
			Spring Pre-comp. (in.)	.019	.019	0.25	0.25	.031	0.31	0.31	.038	0.38	0.44	0.5		
			Stem Travel (in.)	0.19												
	Heavy Duty	-YHNC	Air Pressure (psi)	30	30	35	35	40	40	40	45	45	50	55	36,000	
			Spring Pre-comp. (in.)	0.19	0.19	0.25	0.25	0.31	0.31	0.31	0.38	0.38	0.44	0.5		
			Stem Travel (in.)	0.19												
65V4, 65V6	Medium Duty	-YMNC	Air Pressure (psi)	55	65	65	65	75	75	85	85	85	95	100	65,000	0.08
			Spring Pre-comp. (in.)	0.12	0.19	0.19	0.19	0.25	0.25	0.31	0.31	0.31	0.38	0.38		
			Stem Travel (in.)	0.25												
	Heavy Duty	-YHNC	Air Pressure (psi)	30	35	35	35	40	40	45	45	45	50	55	65,000	
			Spring Pre-comp. (in.)	0.12	0.19	0.19	0.19	0.25	0.25	0.31	0.31	0.31	0.38	0.44		
			Stem Travel (in.)	0.25												
65V9	Medium Duty	-YMNC	Air Pressure (psi)	55	65	65	75	75	85	95	95	95	95	100	65,000	0.14
			Spring Pre-comp. (in.)	0.12	0.19	0.19	0.25	0.25	0.31	0.38	0.38	0.44	0.50	0.56		
			Stem Travel (in.)	0.25												
	Heavy Duty	-YHNC	Air Pressure (psi)	30	35	35	40	40	45	50	50	50	50	55	65,000	
			Spring Pre-comp. (in.)	0.12	0.19	0.19	0.25	0.25	0.31	0.38	0.38	0.44	0.50	0.56		
			Stem Travel (in.)	0.25												
101V5	Heavy Duty	-YHNC	Air Pressure (psi)	35	35	40	40	45	50	60	70	80	90	101	90,000	0.09-0.07
			Spring Pre-comp. (in.)	0.12	0.12	0.19	0.19	0.22	0.25	0.28	0.31	0.38				
			Stem Travel (in.)	0.12												

* Cv value is for straight pattern vee stem valves. Increase this value by 50% for angle pattern valves. Cv Values vary due to compression of actuator spring, and are adjusted based on system pressure. Values shown are for maximum to minimum stem travel position.

Air Valve Actuators

Air to Close, Normally Open

Order Information

Select the basic manual valve from the appropriate pressure section, then add the actuator suffix number to the end of the manual valve catalog number.

Example: 21V4M071-**YMNO**, medium duty actuator, normally open. This valve can be operated at 22,500 psi with an air supply of 100 psi to the valve actuator.

Technical Information

Max working pressure for actuator See table below for specific valve type

Max operating temperature for actuator -20 °F to +200 °F

Actuator material Anodized Aluminum

Air connection size: 1/8" NPT

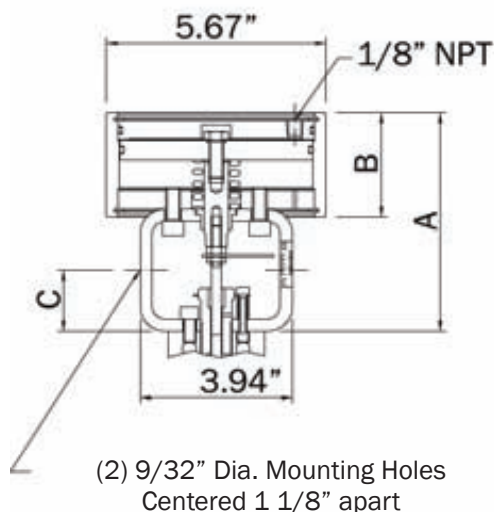

Actuator Type	Valve Size	Ordering Suffix	Piston Area	A	B	C
Medium Duty	1/4" - 3/8" - 9/16"	-YMNO	19.6 in. ³	5.64"	2.69"	1.57"
Heavy Duty	1/4" - 3/8" - 9/16"	-YHNO	39.2 in. ³	7.63"	4.72"	1.57"
Medium Duty	3/4" - 1"	-YMNO	19.6 in. ³	6.43"	2.69"	2.47"
Heavy Duty	3/4" - 1"	-YHNO	39.2 in. ³	8.42"	4.72"	2.47"

Valve Series	Air Actuator		Air Pressure Regulated to Close Valve At: System Pressure (ksi)											Max. Pressure (psi)	Stem Travel (in.)	Flow Value Cv*
	Type	Ordering Suffix	1-3	4	6	8	10	12	14	16	18	20	22			
21V4	Medium Duty	-YMNO	40	40	40	40	50	60	70	70	85	95	100	22,500	0.25	0.31
	Heavy Duty	-YHNO	20	20	20	20	25	30	35	40	45	50	55	22,500		
21V6, 15V4, **	Medium Duty	-YMNO	45	45	45	45	55	65	75	85	95	100	22,500	0.25	0.75	
	Heavy Duty	-YHNO	25	25	25	25	30	35	40	45	50	55	60			22,500
21V9, 15V6, ** 15V8, **	Medium Duty	-YMNO	60	60	65	80	100						10,700	0.38	1.30	
	Heavy Duty	-YHNO	30	30	30	40	50	55	60	70	80	85	90			22,500
21V12	Medium Duty	-YMNO	80	80	100								6,100	0.44	2.50	
	Heavy Duty	-YHNO	40	40	50	60	75	90	100				13,600			
21V16	Heavy Duty	-YHNO	50	50	70	100							8,800	0.56	3.40	

				1-12	14	16	18	20	22	24	26	28	30	36		
36V4	Medium Duty	-YMNO	25	25	30	35	35	40	45	50	50	55	65	36,000	0.19	0.12
	Heavy Duty	-YHNO	15	15	15	20	20	20	25	25	25	30	35	36,000		
36V6 36V9	Medium Duty	-YMNO	30	35	40	45	50	55	60	65	70	72	85	36,000	0.19	0.23
	Heavy Duty	-YHNO	15	20	20	25	25	30	30	35	35	40	50	36,000		

				1-15	20	25	30	35	40	45	50	55	60	65		
65V4 65V6	Medium Duty	-YMNO	30	30	30	35	45	50	55	60	70	75	80	65,000	0.25	0.08
	Heavy Duty	-YHNO	15	15	15	20	25	25	30	30	35	40	45	65,000		
65V9	Medium Duty	-YMNO	35	35	40	50	55	65	70	75	85	90	95	65,000	0.25	0.14
	Heavy Duty	-YHNO	20	20	20	25	30	35	35	40	45	45	50	65,000		

				1-10	20	30	40	50	60	70	80	90	101		
101V5	Medium Duty	-YMNO	50	50	50	50	55	65	75	85	95	100	101,000	0.12	0.09
	Heavy Duty	-YHNO	30	30	30	30	30	35	40	40	45	50	101,000		

* Cv value is for straight pattern vee stem valves. Increase this value by 50% for angle pattern valves. Cv values vary due to compression of actuator spring, and are adjusted based on system pressure. Values shown are for maximum to minimum stem travel position.

** All pipe valves are rated 15,200 psig maximum working pressure, unless air operator is the limiting factor.

All general terms and conditions of sale, including limitations of our liability, apply to all products and services sold.
MT R3 0713