

Medium Pressure Valves, Fittings and Tubing Pressures to 21,000 psi

MAXIMATOR has been designing and manufacturing high pressure equipment for more than thirty years and has a worldwide reputation for quality and reliability, backed by one of the best service organizations in the industry.

Medium Pressure Valves feature:

- ▶ Rising stem design.
- ▶ 316SS wetted parts with a 17-4 PH stem provides excellent corrosion resistance.
- ▶ Metal-to-metal seating achieves bubble-tight shut-off, longer stem and seat life, greater durability for repeated open and close cycles.
- ▶ PTFE and carbon packing with metal back-up rings offers reliable stem to body sealing.
- ▶ Non-rotating stem prevents stem to seat galling.
- ▶ Stem sleeve and packing gland materials have been selected to achieve optimum thread cycle life and reduced handle torque. All stem sleeve threads are rolled, assuring smooth operation.
- ▶ Safety weep holes for all pressure connections and packing area.
- ▶ Six different valve body patterns, with choice of vee or regulating type stem tip.

MAXPRO offers a complete line of medium pressure fittings, tubing, check valves, line filters, anti-vibration fittings and safety head assemblies. All medium pressure valves and fittings use the medium pressure style connection. This coned and threaded connection features orifice sizes to match the high flow characteristics of the medium pressure valve, fitting and tubing line.

Note: When selecting multiple items, the pressure rating would be that of the lowest rated component.

Medium Pressure Index

Valves	2-3
Fittings	4
Anti-Vibration Collet Gland Assemblies	5
Tubing	6
Coned and Threaded Nipples	7
Check Valves	8
Line Filters	9
Safety Head Assemblies and Rupture Discs	10

Maxpro Technologies, Inc.
7728 Klier Drive South · Fairview Pennsylvania 16415
Phone: 814-474-9191 · Fax: 814-474-9391
website: www.maxprotech.com

All general terms and conditions of sale, including limitations of our liability, apply to all products and services sold.
MT 1M R1 0109 CD



Printed in the USA

Medium Pressure Valves

Pressures to 21,000 psi



MAXIMATOR medium pressure valves with metal to metal seats have a high level of safety and reliability under adverse operating conditions. These valves may be used both with gases and liquids.

Traceability is ensured through extensively documented data (batch number, maximum pressure, material number, type designation). All medium pressure valves include glands and collars.

O.D. Size (in.)	Connection Type	Orifice Size (in.)	Rated Cv*	Pressure/Temp. Rating (psi @ R.T.)**
1/4	4MF	0.125	0.31	21,000
3/8	6MF	0.219	0.75	21,000
9/16	9MF	0.312	1.30	21,000
3/4	12MF	0.438	2.50	21,000
1	16MF	0.562	4.40	21,000

* Cv values shown are for 2-way straight pattern vee stem valves.
For 2-way angle patterns, increase the Cv value by 50%.

** See page 2 in the Technical Section for Pressure/Temperature Rating Chart.

Ordering Information

Typical catalog number: **21V4M071**

21V	4M	07	1	OPTIONS
Valve Series	O.D. Tube Size	Stem Type	Body Pattern	Extreme temperature option, see below.
21V	4M - 1/4" 6M - 3/8" 9M - 9/16" 12M - 3/4" 16M - 1"	07 - VEE stem 08 - REGULATING stem (tapered tip for regulating and shutoff) 87 - VEE stem with replaceable seat 88 - REGULATING stem with replaceable seat	1 - two-way straight 2 - two-way angle 3 - three-way, two on pressure 4 - three-way, one on pressure 5 - three-way, two-stem manifold	

Special Designs for Extreme Temperatures

Standard valves are supplied with Teflon/Carbon packing and may be operated to 450°F. High temperature packing and/or extended stuffing box are available for service from -423°F to 1200°F by adding the following suffixes to catalog order number.

- **TG** standard valve with teflon glass packing to 600°F.
- **GY** standard valve with graphite braided yarn packing to 800°F.
- **HT** extended stuffing box valve with graphite braided yarn packing to 1200°F.
- **B** standard valve with cryogenic trim materials and Teflon packing to -100°F.
- **LT** extended stuffing box valve with teflon packing and cryogenic trim materials to -423°F.

Repair Kits

Consult your **MAXPRO** representative for repair kits and valve bodies. Refer to the Tools and Installation section for proper maintenance procedures.

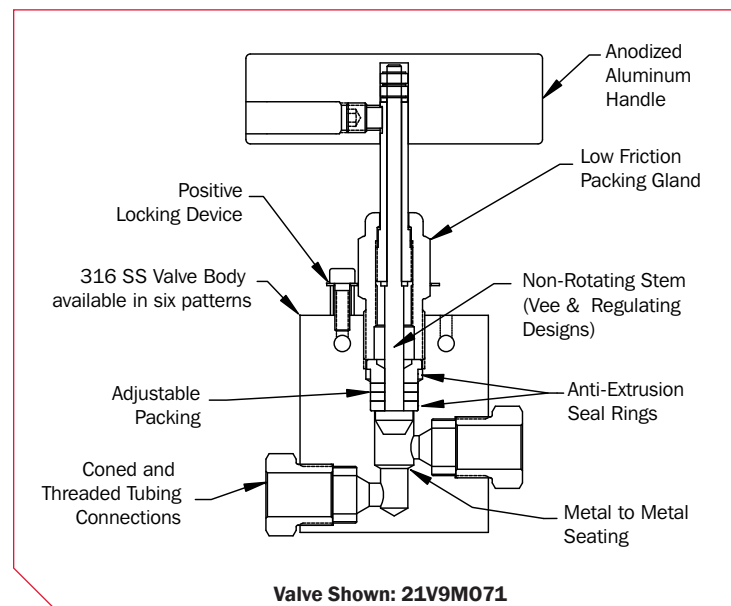
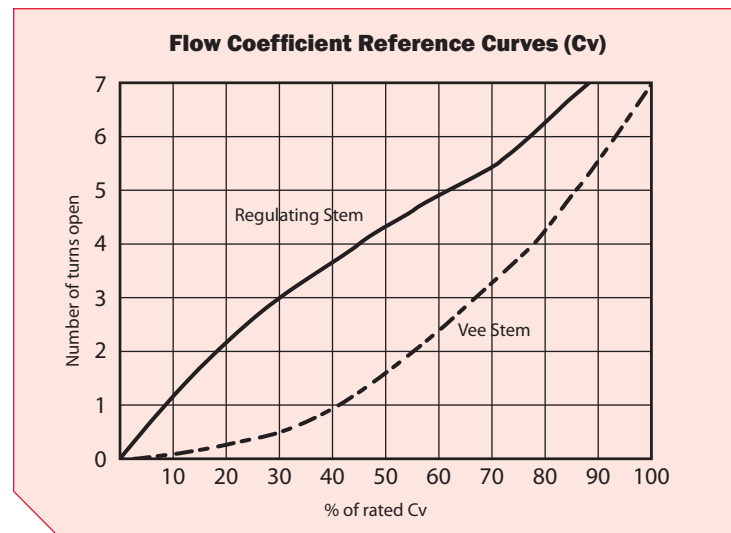

All general terms and conditions of sale, including limitations of our liability, apply to all products and services sold.
MT 1M R1 0109 CD

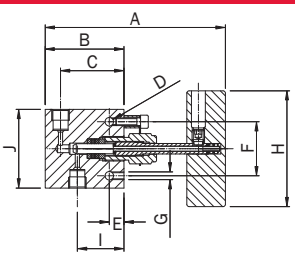
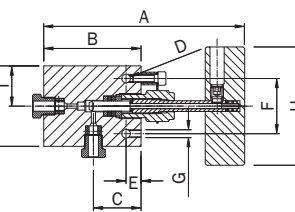
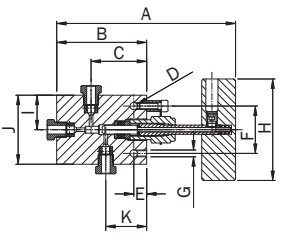
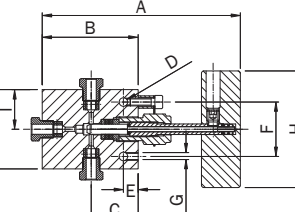
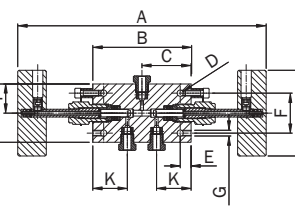
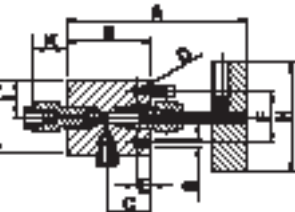
Valve Pattern	Catalog Number	Stem Type	O.D. Tube (in.)	Orifice (in.)	Dimensions (in.)										Valve Panel Hole	Block Thickness	
					A	B	C	D	E	F	H	I	J	K			
2-Way Straight																	
	21V4M071	Vee	1/4	0.125	4.61	2.01	1.62	0.22	0.37	1.24	2.95	1.19	2.01		0.75	0.79	
	21V4M081	Reg															
	21V6M071	Vee	3/8	0.219	4.61	2.01	1.62	0.22	0.37	1.24	2.95	1.19	2.01		0.75	0.79	
	21V6M081	Reg															
	21V9M071	Vee	9/16	0.312	6.35	2.88	2.38	0.37	0.45	1.38	3.94	1.75	2.50		1.00	1.02	
	21V9M081	Reg															
	21V12M071	Vee	3/4	0.438	7.05	3.74	3.00	0.43	0.63	1.76	10.31	2.25	3.00		1.25	1.38	
	21V12M081	Reg															
	21V16M071	Vee	1	0.562	8.98	4.65	3.75	0.53	1.13	2.50	10.31	2.81	4.13		1.62	1.77	
21V16M081	Reg																
2-Way Angle																	
	21V4M072	Vee	1/4	0.125	5.00	2.43	1.19	0.22	0.37	1.24	2.95	1.00	2.01		0.75	0.79	
	21V4M082	Reg															
	21V6M072	Vee	3/8	0.219	5.00	2.43	1.19	0.22	0.37	1.24	2.95	1.00	2.01		0.75	0.79	
	21V6M082	Reg															
	21V9M072	Vee	9/16	0.312	6.85	3.38	1.75	0.37	0.45	1.38	3.94	1.25	2.50		1.00	1.02	
	21V9M082	Reg															
	21V12M072	Vee	3/4	0.438	7.56	4.25	2.25	0.43	0.63	1.76	10.31	1.50	3.00		1.25	1.38	
	21V12M082	Reg															
	21V16M072	Vee	1	0.562	9.45	5.12	2.81	0.53	1.13	2.50	10.31	2.07	4.13		1.62	1.77	
21V16M082	Reg																
3-Way / 2 on Pressure																	
	21V4M073	Vee	1/4	0.125	5.20	2.62	1.62	0.22	0.37	1.24	2.95	1.00	2.01	1.19	0.75	0.79	
	21V4M083	Reg															
	21V6M073	Vee	3/8	0.219	5.20	2.62	1.62	0.22	0.37	1.24	2.95	1.00	2.01	1.19	0.75	0.79	
	21V6M083	Reg															
	21V9M073	Vee	9/16	0.312	7.09	3.62	2.38	0.37	0.45	1.38	3.94	1.25	2.50	1.75	1.00	1.02	
	21V9M083	Reg															
	21V12M073	Vee	3/4	0.438	7.97	4.63	3.00	0.43	0.63	1.76	10.31	1.50	3.00	2.25	1.25	1.38	
	21V12M083	Reg															
	21V16M073	Vee	1	0.562	10.20	5.87	3.75	0.53	1.13	2.50	10.31	2.07	4.13	2.81	1.62	1.77	
21V16M083	Reg																
3-Way / 1 on Pressure																	
	21V4M074	Vee	1/4	0.125	5.00	2.43	1.19	0.22	0.37	1.24	2.95	1.00	2.01		0.75	0.79	
	21V4M084	Reg															
	21V6M074	Vee	3/8	0.219	5.00	2.43	1.19	0.22	0.37	1.24	2.95	1.00	2.01		0.75	0.79	
	21V6M084	Reg															
	21V9M074	Vee	9/16	0.312	6.85	3.38	1.75	0.37	0.45	1.38	3.94	1.25	2.50		1.00	1.02	
	21V9M084	Reg															
	21V12M074	Vee	3/4	0.438	7.56	4.25	2.25	0.43	0.63	1.76	10.31	1.50	3.00		1.25	1.38	
	21V12M084	Reg															
	21V16M074	Vee	1	0.562	9.53	5.12	2.81	0.53	1.13	2.50	10.31	2.07	4.13		1.62	1.77	
21V16M084	Reg																
3-Way / 2-Stem Manifold																	
	21V4M075	Vee	1/4	0.125	8.54	3.39	1.69	0.22	0.37	1.24	2.95	1.00	2.01	1.19	0.75	0.79	
	21V4M085	Reg															
	21V6M075	Vee	3/8	0.219	8.54	3.39	1.69	0.22	0.37	1.24	2.95	1.00	2.01	1.19	0.75	0.79	
	21V6M085	Reg															
	21V9M075	Vee	9/16	0.312	12.06	5.12	2.56	0.37	0.45	1.38	3.94	1.25	2.50	1.75	1.00	1.02	
	21V9M085	Reg															
	21V12M075	Vee	3/4	0.438	13.07	6.50	3.25	0.43	0.63	1.76	10.31	1.50	3.00	2.25	1.25	1.38	
	21V12M085	Reg															
	21V16M075	Vee	1	0.562	16.18	7.52	3.76	0.53	1.13	2.50	10.31	2.07	4.13	2.81	1.62	1.77	
21V16M085	Reg																
2-Way Angle / Replaceable Seat																	
	21V4M872	Vee	1/4	0.125	4.84	2.25	1.19	0.22	0.37	1.24	2.95	1.00	2.01	0.89	0.75	0.79	
	21V4M882	Reg															
	21V6M872	Vee	3/8	0.219	4.84	2.25	1.19	0.22	0.37	1.24	2.95	1.00	2.01	1.02	0.75	0.79	
	21V6M882	Reg															
	21V9M872	Vee	9/16	0.312	6.68	3.21	1.75	0.37	0.45	1.38	3.94	1.25	2.50	1.10	1.00	1.02	
	21V9M882	Reg															
	21V12M872	Vee	3/4	0.438	7.56	4.25	2.25	0.43	0.63	1.76	10.31	1.50	3.00	1.46	1.25	1.38	
	21V12M882	Reg															
	21V16M872	Vee	1	0.562	9.57	5.25	2.81	0.53	1.13	2.50	10.31	2.07	4.13	1.74	1.62	1.77	
21V16M882	Reg																





Medium Pressure Fittings

Pressures to 21,000 psi



MAXIMATOR medium pressure fittings are designed with the large orifice for use with the 21V series medium pressure valves and medium pressure tubing. All medium pressure fittings have coned and threaded type connections. Mounting holes are standard on all elbows, tees, and crosses.

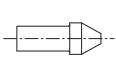

Tubing Size (in.)	Gland	Collar	Plug	Tubing Cap
1/4				
3/8	21G4M	21C4M	21P4M	21TC4M
9/16	21G6M	21C6M	21P6M	21TC6M
3/4	21G9M	21C9M	21P9M	21TC9M
1	21G12M	21C12M	21P12M	21TC12M
	21G16M	21C16M	21P16M	21TC16M

Connection Components

All medium pressure fittings are supplied with glands and collars. Refer to the adjacent chart for ordering any of the connection components individually. When using the plug, the collar is not needed.

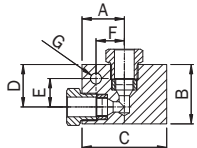
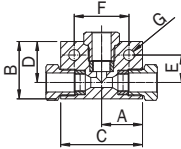
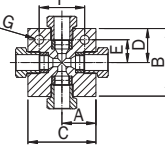
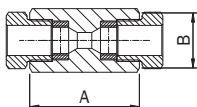
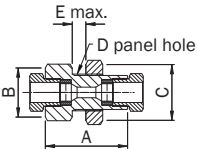
Fitting Pattern	Catalog Number	Connection Type	O.D. Tube Size (in.)	Orifice (in.)	Dimensions (in.)							Block Thickness
					A	B	C	D	E	F	G	
Elbow												
	21L4M	4MF	1/4	0.125	0.75	1.10	1.54	0.75	0.49	0.49	0.22	0.63
	21L6M	6MF	3/8	0.219	1.00	1.38	2.00	1.00	0.63	0.63	0.26	0.79
	21L9M	9MF	9/16	0.359	1.25	1.75	2.50	1.25	0.84	0.84	0.33	1.02
	21L12M	12MF	3/4	0.516	1.50	2.25	3.00	1.50	1.00	1.00	0.35	1.38
	21L16M	16MF	1	0.688	2.06	3.00	4.13	2.06	1.38	1.38	0.53	1.77
Tee												
	21T4M	4MF	1/4	0.125	0.75	1.10	1.54	0.75	0.49	0.98	0.22	0.63
	21T6M	6MF	3/8	0.219	1.00	1.38	2.00	1.00	0.63	1.26	0.26	0.79
	21T9M	9MF	9/16	0.359	1.25	1.75	2.50	1.25	0.84	1.68	0.33	1.02
	21T12M	12MF	3/4	0.516	1.50	2.25	3.00	1.50	1.00	2.00	0.35	1.38
	21T16M	16MF	1	0.688	2.06	3.00	4.13	2.06	1.38	2.76	0.53	1.77
Cross												
	21X4M	4MF	1/4	0.125	0.77	1.54	1.54	0.77	0.49	0.98	0.22	0.63
	21X6M	6MF	3/8	0.219	1.00	2.00	2.00	1.00	0.63	1.26	0.26	0.79
	21X9M	9MF	9/16	0.359	1.25	2.50	2.50	1.25	0.84	1.67	0.33	1.02
	21X12M	12MF	3/4	0.516	1.50	3.00	3.00	1.50	1.00	2.00	0.35	1.38
	21X16M	16MF	1	0.688	2.06	4.13	4.13	2.06	1.38	2.76	0.53	1.77
Straight Coupling / Union Coupling												
	21F4M	4MF	1/4	0.125	1.62	0.69	Straight Coupling					
	21UF4M						Union Coupling					
	21F6M	6MF	3/8	0.219	1.75	0.88	Straight Coupling					
	21UF6M						Union Coupling					
	21F9M	9MF	9/16	0.359	2.12	1.06	Straight Coupling					
	21UF9M						Union Coupling					
	21F12M	12MF	3/4	0.516	2.50	1.44	Straight Coupling					
	21UF12M						Union Coupling					
21F16M	16MF	1	0.688	3.50	2.00	Straight Coupling						
21UF16M						Union Coupling						
Bulkhead Coupling												
	21BF4M	4MF	1/4	0.125	1.88	1.06	1.06	0.94	0.67			
	21BF6M	6MF	3/8	0.219	2.01	1.06	1.06	0.94	0.50			
	21BF9M	9MF	9/16	0.359	2.38	1.44	1.44	1.19	0.38			
	21BF12M	12MF	3/4	0.516	2.81	1.62	1.62	1.44	0.47			
	21BF16M	16MF	1	0.688	3.54	2.00	2.00	1.68	0.51			

All dimensions are for reference only and are subject to change.

See page 2 in the Technical Section for pressure/temperature rating chart.

All general terms and conditions of sale, including limitations of our liability, apply to all products and services sold.

MT 1M R1 0109 CD

MAXIMATOR anti-vibration collet gland assemblies are for use in applications where there could be extreme external mechanical vibrations or shock in tubing lines. These collet gland assemblies are interchangeable with the standard medium pressure coned and threaded tube connections.

In a normal coned and threaded tube connection, any external mechanical loading on the tubing lines, valves or fittings would be concentrated on the first thread of the tube. This can cause failure of the tube at this thinner cross-section. The anti-vibration collet gland assembly grips the tube behind the connection, supporting the tube at the full cross-section and straight area, moving the loading away from the threaded area.

The back part of the assembly has a gland nut that, when tightened properly, compresses a split collet on the tube, providing the beneficial gripping action.

All anti-vibration collet gland assemblies come with a Molybdenum Disulfide Coating to guard against galling of the stainless components.



Gland Pattern	Catalog Number	Part	O.D. Tubing Size (in.)	Dimensions (in.)			
				A	B (Hex.)	C (Hex.)	D
	21AVA4M	Complete Assembly	1/4	1.26	0.62	0.63	1.06
	21AVB4M	Collet Body					
	21AVC4M	Slotted Collet					
	21AVG4M	Gland Nut					
	21AVA6M	Complete Assembly	3/8	1.56	0.81	0.81	1.30
	21AVB6M	Collet Body					
	21AVC6M	Slotted Collet					
	21AVG6M	Gland Nut					
	21AVA9M	Complete Assembly	9/16	1.91	0.94	0.94	1.60
	21AVB9M	Collet Body					
	21AVC9M	Slotted Collet					
	21AVG9M	Gland Nut					
	21AVA12M	Complete Assembly	3/4	2.02	1.25	1.25	1.60
	21AVB12M	Collet Body					
	21AVC12M	Slotted Collet					
	21AVG12M	Gland Nut					
21AVA16M	Complete Assembly	1	2.44	1.50	1.50	1.77	
21AVB16M	Collet Body						
21AVC16M	Slotted Collet						
21AVG16M	Gland Nut						

All dimensions are for reference only and subject to change.

Medium Pressure Tubing

Pressures to 21,000 psi



MAXIMATOR offers a line of cold drawn thick wall tubing, with flow areas to compliment the large orifice medium pressure valves and fittings. This tubing is made under strict manufacturing and quality control standards and inspections, with dimensional tolerances to match the requirements of the medium pressure coned and threaded connections.

The standard materials are 304 and 316 stainless steels. Other materials may be provided on special request, depending on the specific material, diameters and lengths.



Tubing Tolerances

Normal Tubing Size (in.)	Tolerance O.D. (in.)
1/4	0.248 / 0.243
3/8	0.370 / 0.365
9/16	0.557 / 0.552
3/4	0.745 / 0.740
1	0.995 / 0.990

Catalog Number	Tube Material	Fits Connection Type	Tube Size (in.)		Working Pressure (psi)				
			O.D.	I.D.	-325 to 100°F	200°F	400°F	600°F	800°F
21TU4M-316	316SS	4MF	1/4	0.109	21,000	18,900	17,430	15,960	15,120
21TU4M-304	304SS								
21TU6M-316	316SS	6MF	3/8	0.203	21,000	18,900	17,430	15,960	15,120
21TU6M-304	304SS								
21TU9M-316	316SS	9MF	9/16	0.312	21,000	18,900	17,430	15,960	15,120
21TU9M-304	304SS								
15TU9M-316	316SS	9MF	9/16	0.359	15,200	13,680	12,616	11,552	10,944
15TU9M-304	304SS								
21TU12M-316	316SS	12MF	3/4	0.438	21,000	18,900	17,430	15,960	15,120
15TU12M-316	316SS			0.516	15,200	13,680	12,616	11,552	10,944
21TU16M-316	316SS	16MF	1	0.562	21,000	18,900	17,430	15,960	15,120
15TU16M-316	316SS			0.688	15,200	13,680	12,616	11,552	10,944

All dimensions are for reference only and subject to change.

All general terms and conditions of sale, including limitations of our liability, apply to all products and services sold.
MT 1M R1 0109 CD



MAXIMATOR offers a line of coned and threaded medium pressure tube nipples in a variety of lengths for all standard tube sizes.

The coned and threaded medium pressure tube nipples are available in 316 stainless steel. They are also available in the 15,200 psi or 21,000 psi versions for the 9/16", 3/4" and 1" OD tube sizes. See chart below for ordering information.

Special length coned and threaded nipples are available upon request. Consult **MAXPRO** for availability and price.

Catalog Numbers are 316 Stainless Steel material							Fits Connection Type	Tube Size (in.)		Working Pressure at 100 °F (psi)
2.75" Length	3" Length	4" Length	6" Length	8" Length	10" Length	12" Length		O.D.	I.D.	
21N4M-2.75-316	21N4M-3-316	21N4M-4-316	21N4M-6-316	21N4M-8-316	21N4M-10-316	21N4M-12-316	4MF	1/4	0.109	21,000
	21N6M-3-316	21N6M-4-316	21N6M-6-316	21N6M-8-316	21N6M-10-316	21N6M-12-316	6MF	3/8	0.203	21,000
	21N9M-3-316	21N9M-4-316	21N9M-6-316	21N9M-8-316	21N9M-10-316	21N9M-12-316	9MF	9/16	0.312	21,000
		15N9M-4-316	15N9M-6-316	15N9M-8-316	15N9M-10-316	15N9M-12-316	9MF	9/16	0.359	15,200
		21N12M-4-316	21N12M-6-316	21N12M-8-316	21N12M-10-316	21N12M-12-316	12MF	3/4	0.438	21,000
			15N12M-6-316	15N12M-8-316	15N12M-10-316	15N12M-12-316	12MF	3/4	0.516	15,200
			21N16M-6-316	21N16M-8-316	21N16M-10-316	21N16M-12-316	16MF	1	0.562	21,000
			15N16M-6-316	15N16M-8-316	15N16M-10-316	15N16M-12-316	16MF	1	0.688	15,200

Standard nipples are not supplied with glands and collars, see Fittings on page 4 for these components.

See adjacent Tubing page 6, for pressure/temperature rating chart.

All dimensions are for reference only and subject to change.

O-Ring Check Valves



O-Ring Check Valves

MAXIMATOR o-ring check valves provide high quality directional flow control and tight shutoff for liquids and gases. All check valves are supplied with glands and collars. These check valves are not to be used as a relief device.

Materials.

Body, cover, poppet, cover gland: 316 series stainless steel
 Spring: 300 series stainless steel
 O-ring: Viton "A" (-4 °F to 392 °F)

Ball Check Valves



Ball Check Valves

MAXIMATOR ball check valves prevent reverse flow where bubble tight shutoff is not mandatory. These check valves are designed with a ball cradled floating poppet to assure positive inline seating. This poppet design allows full flow around the ball to minimize pressure drop. Check valves are rated to 660 °F. All check valves are supplied with glands and collars. These check valves are not to be used as a relief device.

Materials.

Body, cover, poppet, cover gland: 316 series stainless steel
 Ball and spring: 300 series stainless steel

Valve Pattern	Catalog Number	Pressure Rating (psi)	O.D. Tube (in.)	Connection Type	Orifice (in.)	Rated (Cv)	Dimensions (in.)	
							A (Hex.)	B

O-Ring Check Valves

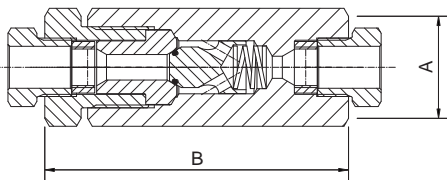

210C4M	21,000	1/4	4MF	0.125	0.28	0.88	2.91
210C6M	21,000	3/8	6MF	0.219	0.84	1.06	3.33
210C9M	21,000	9/16	9MF	0.359	2.30	1.44	4.29
210C12M	21,000	3/4	12MF	0.516	4.70	2.00	5.43
210C16M	21,000	1	16MF	0.688	7.40	2.00	6.57

Ball Check Valves

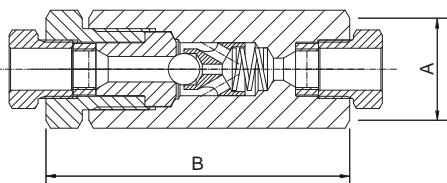

21BC4M	21,000	1/4	4MF	0.125	0.28	0.88	2.91
21BC6M	21,000	3/8	6MF	0.219	0.84	1.06	3.33
21BC9M	21,000	9/16	9MF	0.359	2.30	1.44	4.29
21BC12M	21,000	3/4	12MF	0.516	4.70	2.00	5.43
21BC16M	21,000	1	16MF	0.688	7.40	2.00	6.57

CAUTION: FREQUENT INSPECTIONS of O-Rings are necessary to ensure proper service of the check valve. O-Rings have shown satisfactory service life in testing, however different service conditions may lead to variations in cycle and shelf life.

All dimensions are for reference only and subject to change.

Dual-Disc Line Filters

MAXIMATOR dual-disc line filters are used to filter process fluids in high pressure systems. This design helps remove the large particles first through a coarse primary disc, which then allows a secondary disc to provide a smaller micron filtration. These filter elements are designed to withstand pressure surges without cracking, flaking, or rupturing. Filter elements come standard in the following micron sizes: 5/8, 8/30, 30/56 (secondary/primary). Filters are rated for temperatures -60 °F to 660 °F. All line filters come with glands and collars.

Materials

Body: cover, cover gland: 316 series stainless steel
Element: 300 series stainless steel

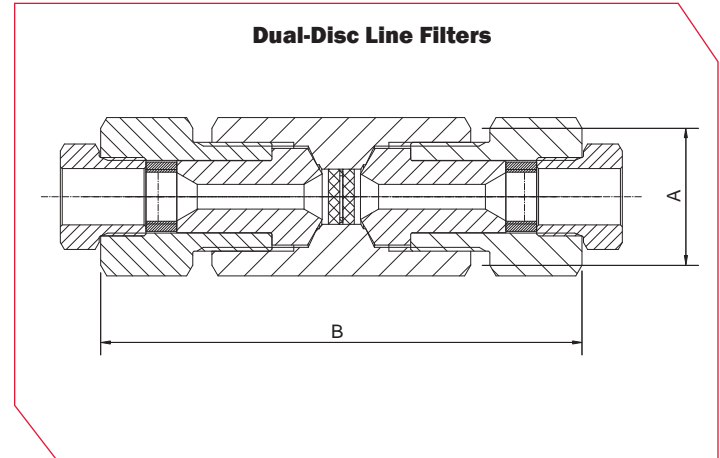

Cup-Type Line Filters

MAXIMATOR cup-type line filters are used when maximum filtration surface area and a single micron size element is preferred. This design increases the filter area as much as 6 times the area of the disc type filter, and will permit higher flow rates with a lower pressure drop, and longer intervals between element changes. Filter elements come standard in 5, 30, or 56 micron sizes and are easily replaced. Filters are rated for temperatures -60 °F to 660 °F. All line filters come with glands and collars.

Materials:

Body, cover, cover gland: 316 series stainless steel
Element: 300 series stainless steel

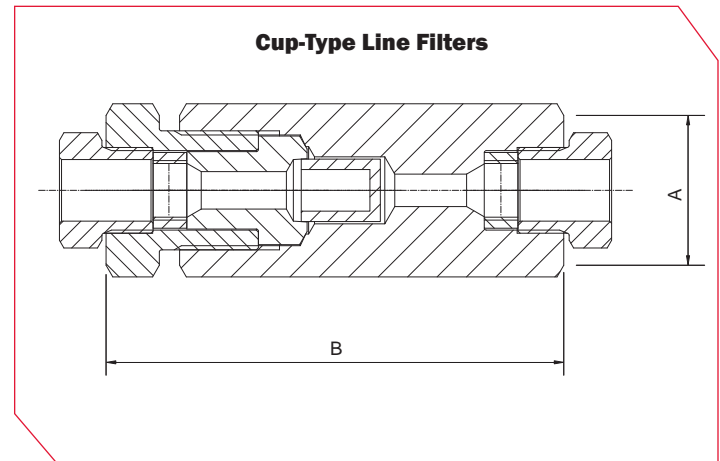

Catalog Number	Pressure Rating (psi)	O.D. Tube (in.)	Connection Type	Orifice (in.)	Micron Size	Filter Element Area (in. ²)	Dimensions (in.)	
							A (Hex.)	B
Dual-Disc Line Filters								
21DF9M - 5/8	21,000	9/16	9MF	0.312	5/8	0.25	1.44	4.96
21DF9M - 8/30					8/30			
21DF9M - 30/56					30/56			
Cup-Type Line Filters								
21CF4M-5	21,000	1/4	4MF	0.125	5	0.82	0.88	2.87
21CF4M-30					30			
21CF4M-56					56			
21CF6M-5	21,000	3/8	6MF	0.219	5	0.82	1.06	3.35
21CF6M-30					30			
21CF6M-56					56			
21CF9M-5	21,000	9/16	9MF	0.359	5	1.55	1.44	4.33
21CF9M-30					30			
21CF9M-56					56			
21CF12M-5	21,000	3/4	12MF	0.516	5	6.14	2.00	6.57
21CF12M-30					30			
21CF12M-56					56			
21CF16M-5	21,000	1	16MF	0.688	5	6.14	2.00	6.57
21CF16M-30					30			
21CF16M-56					56			

It is recommended that all fluids entering a high pressure system be thoroughly cleaned. Maximator filters are designed to remove small amounts of process particles. Pressure differential should not exceed 1000 psi across the filter elements.

All dimensions for reference only and are subject to change.

Safety Head Assembly

Pressures to 21,000 psi

MAXIMATOR safety head assemblies are used to provide over-pressure protection to high pressure systems. These safety head assemblies are to be used with the appropriate 1/4" angular rupture disc listed in the chart below.

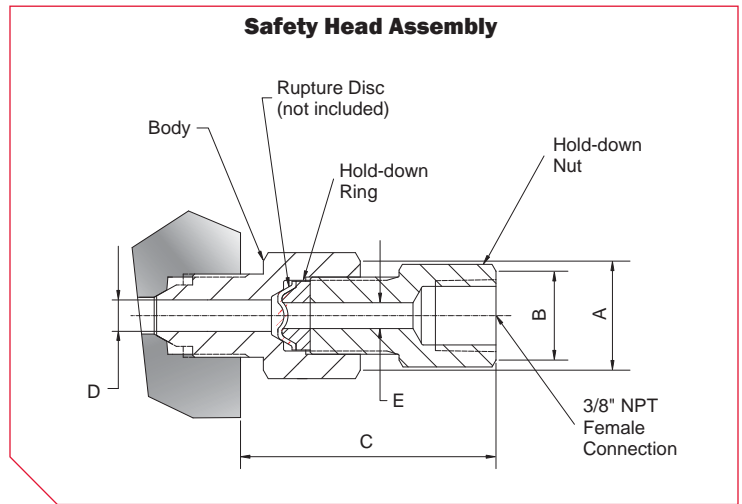
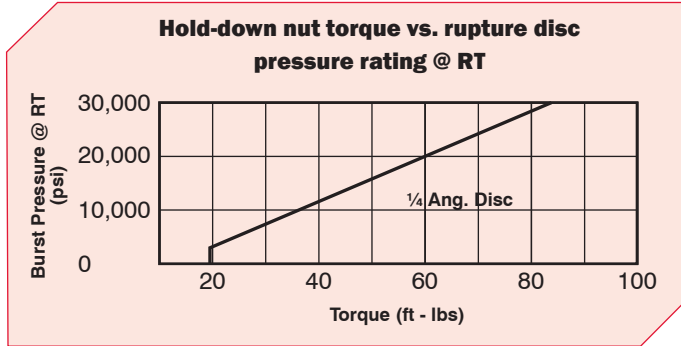

Safety Head Assembly Catalog Number without Disc	Fits Connection Type	O.D. Tube (in.)	Pressure Rating (psi)	Body Torque (ft - lbs.)	Dimensions (in.)				
					A (Hex.)	B (Hex.)	C (LG.)	D (I.D.)	E (I.D.)
21SH4M	4MF	1/4	21,000	20	1.06	0.88	2.69	0.109	0.250
21SH6M	6MF	3/8	21,000	30	1.06	0.88	2.72	0.203	0.250
21SH9M	9MF	9/16	21,000	55	1.06	0.88	2.47	0.312	0.250
21SH12M	12MF	3/4	21,000	90	1.19	0.88	2.72	0.312	0.250
21SH16M	16MF	1	21,000	150	1.44	0.88	2.72	0.312	0.250

All dimensions for reference only and are subject to change.

1/4" Angular Rupture Discs



1/4" angular seat rupture discs are designed to be used with the safety head assemblies that are shown above. Minimum rupture disc pressure ratings should be at least 110% of system operating pressure. The standard material is Inconel. The pressure ranges indicated in the table below are at room temperature (72°F). Other materials and pressure ranges are available upon request.

Catalog Number	Pressure range (psi)
RD-1000	970 - 1,060
RD-1200	1,164 - 1,272
RD-1500	1,455 - 1,590
RD-1750	1,697 - 1,855
RD-2000	1,940 - 2,120
RD-2500	2,425 - 2,650
RD-3000	2,910 - 3,180
RD-3500	3,395 - 3,710
RD-4000	3,880 - 4,240
RD-4500	4,365 - 4,770
RD-5000	4,850 - 5,300

Catalog Number	Pressure range (psi)
RD-5500	5,335 - 5,830
RD-6000	5,820 - 6,360
RD-6500	6,305 - 6,890
RD-7000	6,790 - 7,420
RD-7500	7,275 - 7,950
RD-8000	7,760 - 8,480
RD-8500	8,245 - 9,010
RD-9000	8,730 - 9,540
RD-9500	9,215 - 10,070
RD-10000	9,700 - 10,600
RD-11000	10,670 - 11,660

Catalog Number	Pressure range (psi)
RD-12000	11,640 - 12,720
RD-13000	12,610 - 13,780
RD-14000	13,580 - 14,840
RD-15000	14,550 - 15,900
RD-16000	15,520 - 16,960
RD-17000	16,490 - 18,020
RD-18000	17,460 - 19,080
RD-19000	18,430 - 20,140
RD-20000	19,400 - 21,200
RD-21000	20,370 - 22,260
RD-22000	21,340 - 23,320